

Aesculap Orthopaedics

Prevision®

Revision Endoprosthesis - modular



PREVISION® – the concept

Bridging the defects. Secure implant fixation.



Temporary distal interlocking strengthens the hold of the Prevision® revision endoprosthesis and facilitates the return to proximal force transfer following successful bone regeneration.

The distal interlocking of the Prevision® stem with screws improves the stability of the implant in large bone defects. The defective zones are bridged and proximal bone areas can regenerate. Regeneration of the proximal bone can be assisted with allogeneous bone or through the transfemoral approach technique. Removal of

the interlocking screws after successful bone regeneration results in a renewed proximal force transfer. The Prevision® "reverse principle" offers the possibility of influencing the effects of an exclusively distal force transfer on the proximal bone structures.

Depending on the bone defect, the proximal section of the Prevision® revision prosthesis takes on a new load bearing function at an early stage. For low grade bone defects and intact proximal femurs, distal interlocking can be used for additional temporary implant stabilization.





Major bone defects and poor bone quality require special techniques for revision surgery. The securely bedded, stable prosthesis bridges the weak bone system. The biological revision approach supports bone regeneration and does not merely replace the missing bone with avital material. Bone must be able to regenerate itself in order to become load bearing again.

The Prevision® philosophy supports the biological revision technique.

Following the reverse principle, it reverts from temporary stable distal fixation to proximal force transfer.

Plasmapore® μ -CaP surface assists and accelerates bone contact on the proximal surface of the Prevision® stem.

Plasmapore® μ -CaP coating on the proximal section of the Prevision® revision stem supports bone contact through the emission of calcium and phosphate ions.

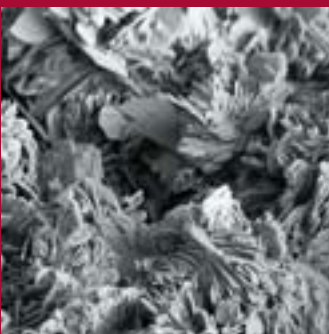

The proximal component of the Prevision® revision prosthesis is coated with Plasmapore® μ -CaP surface, a semicrystalline calcium phosphate (CaP). In an electrochemical process, calcium phosphate of high purity is combined with the Plasmapore® titanium surface at a layer depth of 20 μ m.

Thanks to the osteoconductive properties of the dicalcium phosphate (μ -CaP), the bone forms more rapid direct contact with the implant surface. This effect, combined with continuous calcium and phosphate degradation and ion emission, is the essential purpose of the Plasmapore® μ -CaP surface.

The Aesculap Scientific Information sheet 051002 contains more information on Plasmapore® μ -CaP.

PREVISION® – the product

Adapt the implant. Regenerate the bone.

The Prevision® revision components are built up step by step according to a coordinated dimension concept.

The variety of proximal components and their total compatibility with the distal shafts mean that each individual implant can be optimally adapted to the particular defect situation.



The range of Prevision® implant components offers a large degree of freedom in combining the individual elements to achieve a precise match with the particular bone, defect and joint situation.

The Prevision® revision prosthesis comprises a comprehensive range of over 250 possible combinations. A selection of implants with distal diameters from 12 mm to 24 mm and implant lengths from 240 mm to 400 mm is available as standard. For optimum reconstruction of the hip joint and leg length it is also possible, in addition to these

40 mm length increments, to use the proximal components for finer adjustment since each proximal implant size is available in length increments of 0 mm, + 10 mm and + 20 mm. Because the implant components can be assembled in situ, the leg length can be adjusted easily and at the latest possible stage in the implantation.





Every revision operation places its own particular demands on the implant dimensions. The remaining bone, which is frequently minimal, represents the basis for bone regeneration. The modular implant components are therefore selected with the aim of bone regeneration and not merely of filling the defect.



The catch-free Prevision® cone coupling is a reliable connection mechanism enabling the modular implant components to be connected in situ.



The coupling of the implant components is the central element of any modular endoprosthesis. Prevision® has one single connection point, without restricting the range of combination options. Independent of the implant combination chosen, biomechanical tests confirm reliable long term stability for the Prevision® coupling

system, which is based on a 1:20 conical clamping mechanism with a defined applied frictional connection of 15kN. The catch-free coupling of the implant components permits unrestricted antetorsion adjustment of the proximal implant components - including in situ assembly.

PREVISION[®] – the user

Assisting the surgeon. Anticipating the outcome.





Particularly in difficult tasks, early recognition of the situation and anticipation of the outcome is crucial for making the right decisions and choosing the best way to reach the goal.

*Using Prevision[®], the hip revision specialist will safely and securely achieve the desired outcome:
best possible joint reconstruction
and lasting implant fixation.*

The clear and logical structure of the Prevision[®] instrumentation facilitates forward looking implantation and intraoperative monitoring of the surgical steps.



The Prevision[®] instruments are designed for both transfemoral and proximal implantation of the prosthesis components. A free choice of assembly inside or outside the femur is possible, even for the connection of the distal and proximal components. In addition to reliable preparation of the implant site, the instruments

offer early and repeated opportunities for trial reduction and secure fastening of the proximal and distal implant components. A brace applied to the distal component effectively cancels out the transfer of torque onto the distal implant site during in situ assembly.

PREVISION[®] – preoperative planning

Defect classification

Differentiated diagnosis and careful planning are essential before a revision operation. After evaluation of the initial preoperative situation, the therapeutic procedure and the ideal surgical outcome must be defined. Classification of the type and size of the existing bone defects helps in deciding on the surgical tactic and the resources and implants required to restore the function of the joint.



Type 1
Intramedullary defects



Type 2
Intertrochanteric defects



Type 3
Calcar defects

If the bone defects are only minor (Type 1 - 3) and the femoral shaft is still intact, proximal removal of the prosthesis and bone cement is recommended. A ventral bone window can also be opened for distal bone cement removal.

Because of the minor bone loss, these defects can frequently be treated and stability achieved with primary implants or short revision stems.

Preoperative planning simulates the operation and helps avoid unexpected situations arising during surgery. It lays an important foundation stone for the success of the operation.



Type 4
Medial femur defects



Type 5
Lateral femur defects



Type 6
Circular, segmental femur defects

*Defect classification
according to Katthagen*

Where pronounced bone defects (Type 4 - 6) exist, with partial or complete destruction of the femoral shaft, the transfemoral approach is preferred, since in these situations proximal removal of the implant would entail the risk of further fragmentation.

Opening up the femoral shaft has a major influence on primary stability, and long stemmed implants are required to maintain adequate load bearing capacity.

Periprosthetic fractures are not included in the above mentioned classification scale. In case of further distalized fractures within the knee condyles additional measures to stabilize the fracture are required.

PREVISION® – preoperative planning

Radiograph planning

During preoperative planning the various alternatives are considered, potential sources of complications are identified and the optimum treatment outcome is defined.

Planning is carried out using standardized x-rays (full pelvis x-ray, long femoral x-ray in ap and sagittal projections).

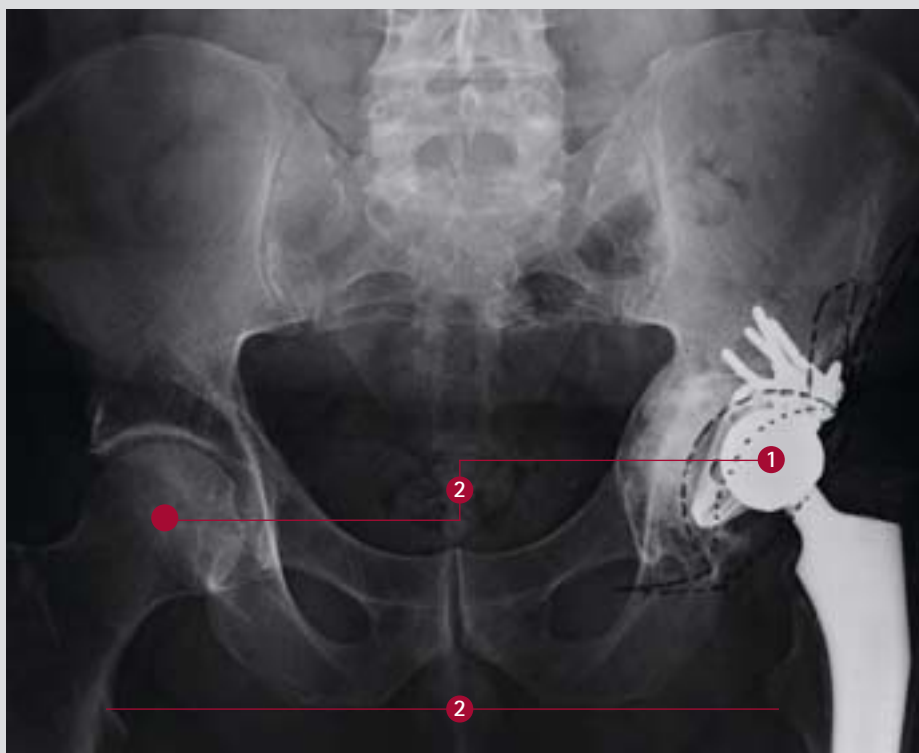

- Establish the x-ray scale
- Identify the existing prosthesis components
- Check whether special explanation instruments or implant components are required

Full pelvis x-ray:

- Plan the treatment of the acetabulum with anticipated joint centre **1**
- Plan the necessary leg length according to the contralateral situation **2**

The various conditions that have led to the revision surgery require careful diagnosis and extensive surgical preparation and planning.

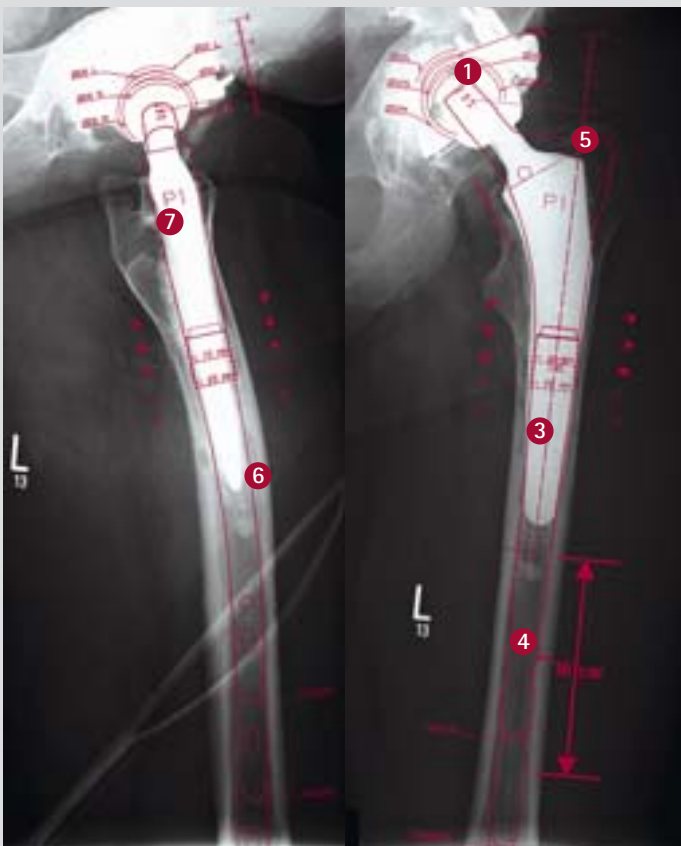

Long ap femoral x-ray:

- Evaluate the defect situation and the bone quality that is to be expected in the prosthesis fixation zone.
- Plan the position of the ventral bone window or of the resection line for the transfemoral approach ③. The length of the resection in the transfemoral approach normally corresponds to the length of the loosened implant.
- Plan the size and length of the distal implant component ④. The distal component should lie against the inner cortex and have a fixation area of at least 10 cm (below the transfemoral osteotomy)
- Assess the bone quality in relation to the distal fixation and the possibility of using locking screws.

- Plan the proximal prosthesis components ⑤ taking account of leg length adjustment ②
- Anatomical orientation points (greater and lesser trochanter) for intraoperative orientation of instruments and implants.

Long sagittal femoral x-ray:

- Check the sagittal position of the prosthesis components ⑥ + ⑦
- General:
- Check the action required for bone reconstruction (allogeneous, autogenous bone material or bone replacement material)

PREVISION[®] – operating technique

Proximal approach

Removal of the loosened prosthesis stem, preparation of the new implant site and implantation of the prosthesis components depend to a crucial extent on the surgical approach selected (proximal or transfemoral technique) and the existing bone situation.



Proximal implant removal



Cement removal with the option of using a bone window

The prosthesis components are exchanged via the existing implantation opening. Any bone cement and granulation tissue found are completely cleared away using special extraction instruments (such as drills, chisels, extractors, hooks and special scoops).

It may also be necessary to create a ventral bone window to remove the bone cement or the implant. This window should be left within the soft tissue structure.

Transfemoral approach

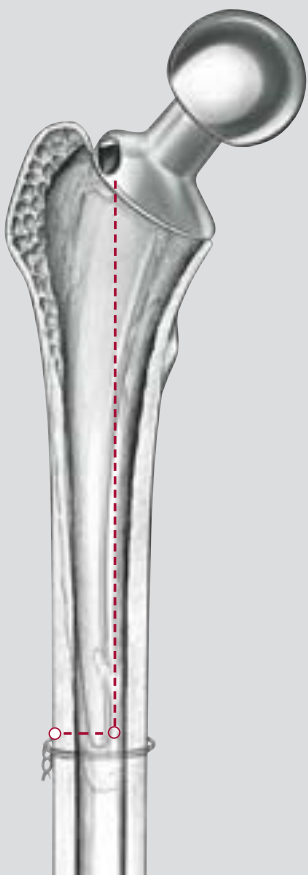

Transfemoral opening
of the femur

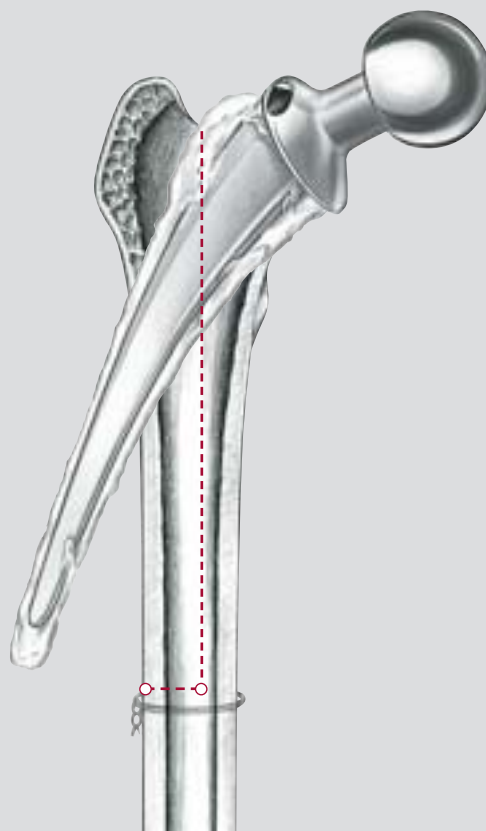

Removal of the
loosened prosthesis

The longitudinal osteotomy of the femur is performed in accordance with the preoperative planning. First, two distal limitation boreholes are set (ventrally and laterally). To protect the femoral bone, a cerclage wire is applied below the limitation boreholes. The lateral osteotomy is performed with an oscillating saw and ends in the

limitation borehole previously set. The two boreholes are then connected. The transosseous medial osteotomy is performed with a chisel which reaches via the lateral osteotomy opening to the contralateral cortex and perforates the bone from the inside.

It is absolutely essential to leave the osteotomised bone flap in the soft tissue structure. It is opened in a medial direction and carefully fixed with bone levers. All manipulations on the leg must be performed with extreme care, since the periprosthetic bone flaps are usually in a substantially weakened condition.

Correcting orientation:
In the case of a loosened prosthesis that has wandered in a lateral direction or the existence of intramedullary bone lamellae, a rigid reamer (Ø 12 mm) can be used to correct the orientation and set the proper implant position in the distal femur.

PREVISION® – operating technique

Preparing the implant site

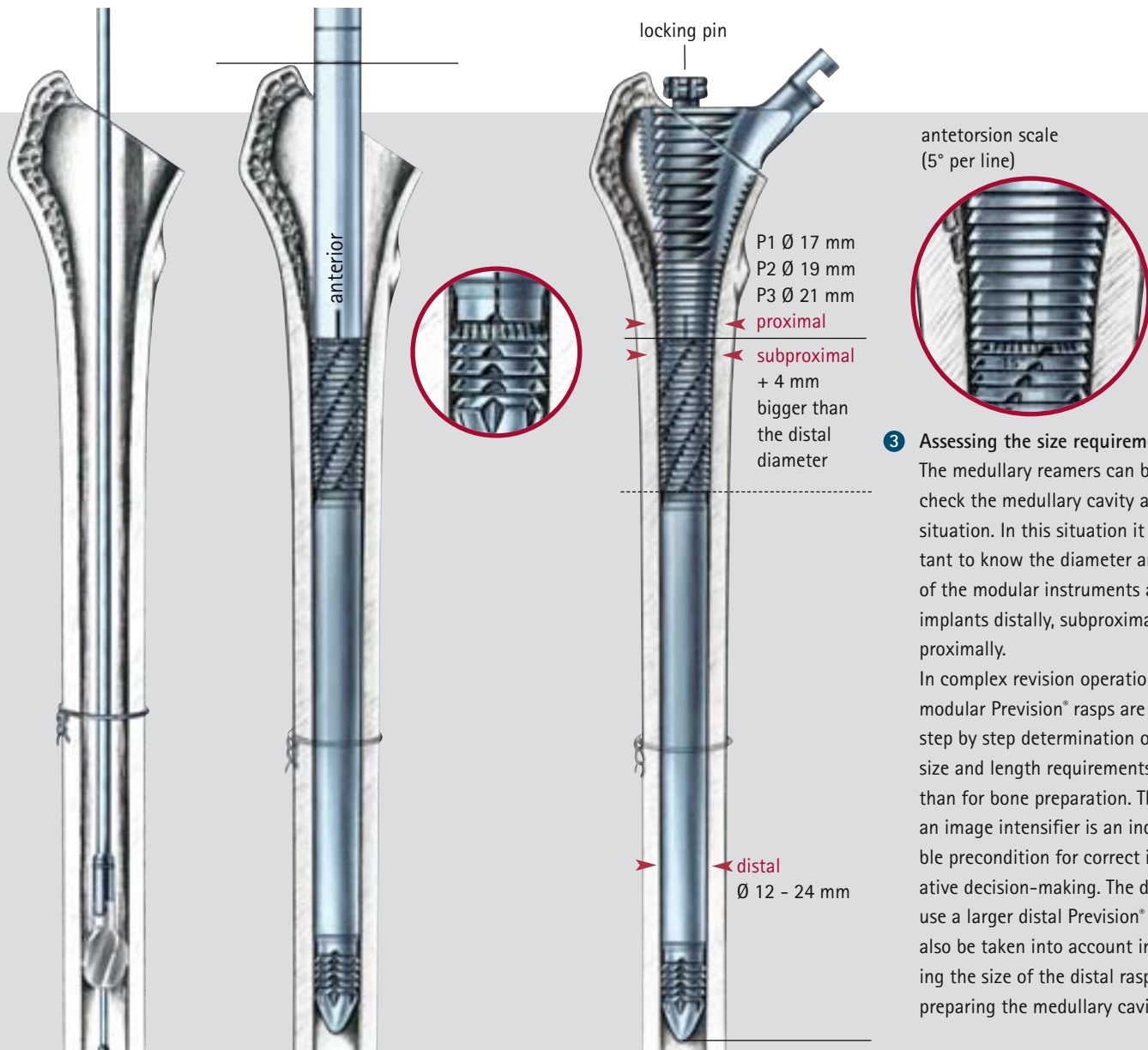

Preparing the distal medullary canal with flexible medullary reamers

Preparing the distal and subproximal implant site

Preparing the subproximal and proximal implant site

3 Assessing the size requirements

The medullary reamers can be used to check the medullary cavity and length situation. In this situation it is important to know the diameter and length of the modular instruments and implants distally, subproximally and proximally.

In complex revision operations, the modular Prevision® rasps are used for step by step determination of implant size and length requirements, rather than for bone preparation. The use of an image intensifier is an indispensable precondition for correct intraoperative decision-making. The decision to use a larger distal Prevision® stem can also be taken into account in choosing the size of the distal rasps and in preparing the medullary cavity.

1 Preparing the distal medullary canal:

The distal implant site is prepared mechanically using flexible medullary reamers (Ø 12 mm - 24 mm). A guide wire guarantees the intramedullary orientation of the medullary reamer. Preparation is carried in stages, if necessary subproximal and proximal, and concludes when cortical contact can be felt.

2 Assembling and using the trial rasps:

The modular rasps serve the preparation of the subproximal and proximal implant site. They can also be used for initial trial reduction. To prepare the trial rasps, the locking pins in the proximal rasp components are screwed in slightly. In selecting the size of the distal rasp components, a smaller diameter is chosen to start with and then each subsequent larger size is

selected in stages. The distal rasp element can be used separately or assembled with the proximal rasp components. In both cases the antetorsion position (see distal curvature) is preset according to the side that is being operated on. The separately used distal rasp is fixed by screwing on the handle for distal rasps. If the distal and proximal rasp components are used together, they are inserted in one another and axial fixed by pressing

the locking pin. The distal component can be turned and if required locked in rotationally fixed position through the complete screwing in of the locking pin. The selection of the rasps occurs based on the proximal size (P1 - P3) and the planned distal prosthesis length (240/280/320/360/400 mm).

Implanting the distal stem

20 mm
10 mm
0 mm — new joint center

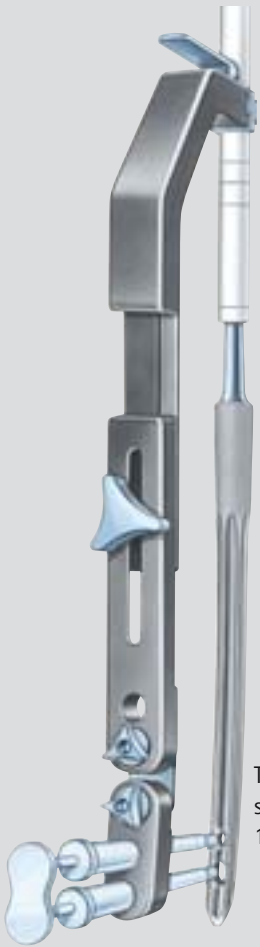

The distal Prevision® stems have a 1200 mm radius.



Adjusting the targeting device to the distal prosthesis

Implanting the distal prosthesis

6 Inserting the distal implant component:

The Prevision® implant components can be assembled both inside and outside the femur. Intraosseous assembly is to be preferred because of the opportunity it offers of building up the implant components step by step.

The selection of the stem size is based on the final distal rasp used and the stem length required. In the transfemoral approach and in

the lack of subproximal support, the next larger implant diameter is selected. The distal implant is fixed firmly onto the implantation instrument.

Under consideration of the curvature of the implant components, the distal stem is driven in. The markings on the implantation instrument show the midpoint of the head of the respective proximal implant components.

4 Trial reduction with the modular rasp:

Trial reduction can be performed with the rasp components. Especially where the implant components are to be assembled outside the femur, trial reduction with the rasp components is absolutely fundamental before selecting and assembling the implant.

5 Distal locking

Where there is inadequate primary stability, and as a matter of principle when using the transfemoral approach, the prosthesis is locked distally. This locking can be performed freehand under image intensifier control or using a special targeting device. If this device is to be used, it is first adjusted to the individual prosthesis before the stem is implanted. To do this, the

targeting device is attached to the implantation instrument that is firmly screwed onto the implant stem and adjusted according to the screw holes on the stem using a targeting guide. The screws of the targeting device are firmly tightened from a proximal to a distal direction.

If the targeting guide becomes twisted, all the screws must be

loosened and the targeting device reorientated and refixed into position to guarantee correct function. The targeting device is then removed and stored safely during implantation of the stem, following which it is reattached. The tissue protection sleeves serve as the working channel for drilling, measuring and inserting the locking screws.

PREVISION[®] – operating technique

Intraosseous assembly



Reduction with the proximal trial component

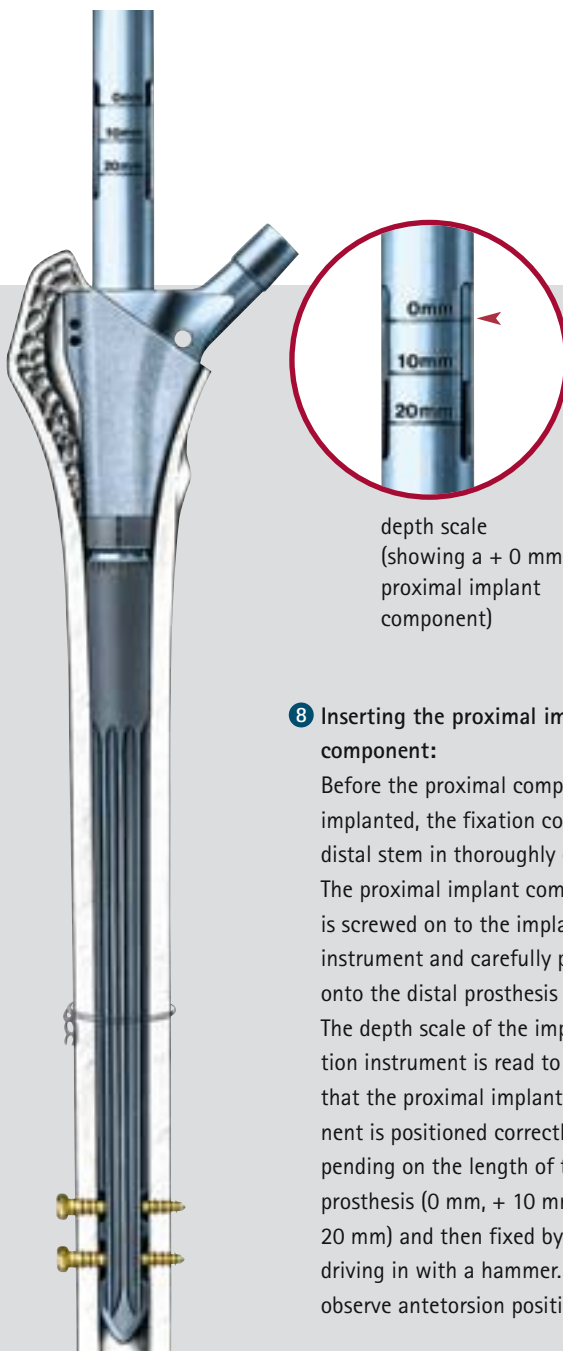

depth scale
(showing a + 0 mm
proximal implant
component)

- 8** Inserting the proximal implant component:
Before the proximal component is implanted, the fixation cone of the distal stem is thoroughly cleaned. The proximal implant component is screwed on to the implantation instrument and carefully placed onto the distal prosthesis shaft. The depth scale of the implantation instrument is read to check that the proximal implant component is positioned correctly depending on the length of the prosthesis (0 mm, + 10 mm, + 20 mm) and then fixed by light driving in with a hammer. Thereby observe antetorsion position.

Inserting the proximal implant component

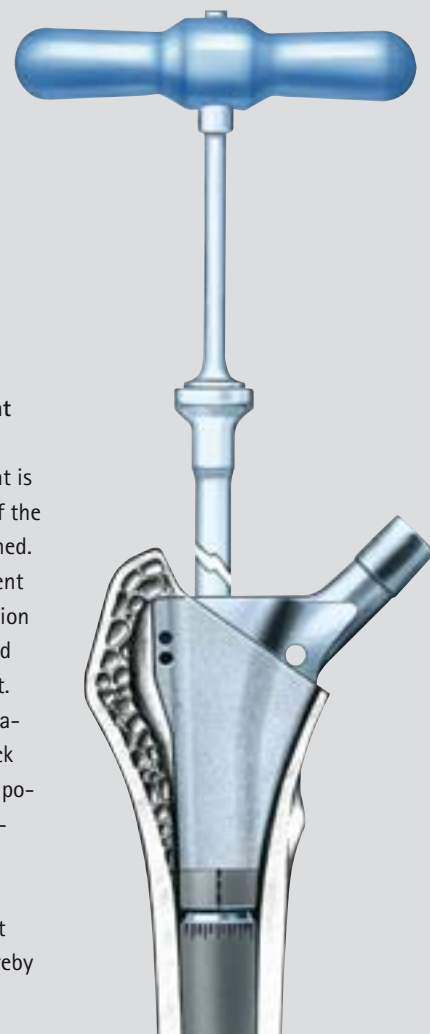

Inserting the tension nut

7 Reduction with the proximal trial component:

The trial components are used to select the proximal implant. The required leg length adjustment can be achieved via the various proximal component lengths. For trial reduction, the trial components are placed onto the distal shaft and fixed with a trial tension nut.

9 Joining the implant components:

The tension nut is removed from the proximal implant packaging, set onto the socket wrench, and manually screwed on the distal implant component. Subsequently, the handle is removed and the adapter rod of the counter holder is inserted through the socket wrench to the connection point of the distal shaft so that it engages.

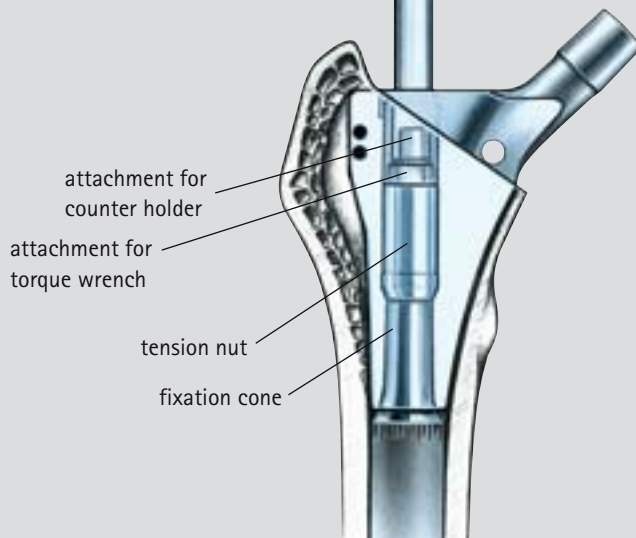
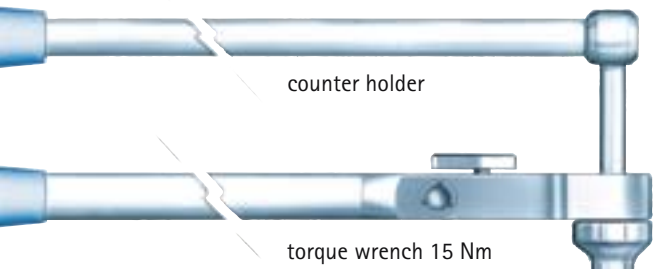

connection the implant components

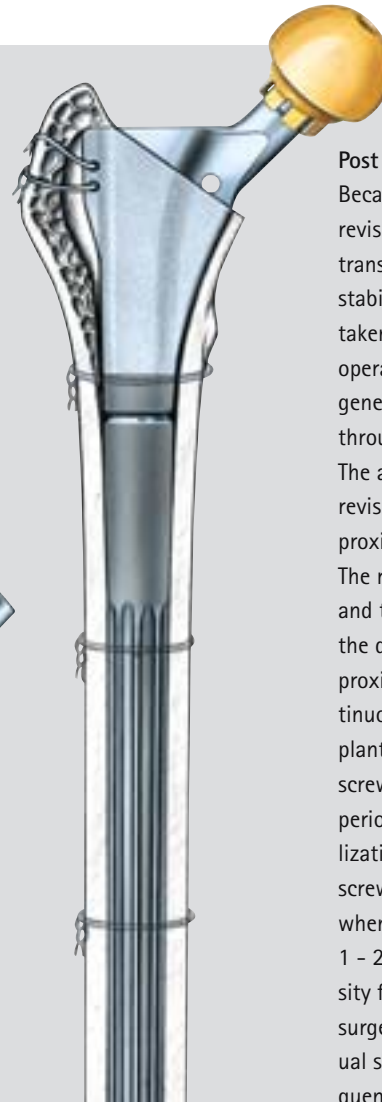

Trial reduction and closure of transfemoral osteotomy

Post operative treatment:
 Because of the initial situation in revision cases and the use of the transfemoral approach, primary stability is reduced. This must be taken into consideration in post operative treatment. The bone regeneration status must be assessed through regular patient follow-up. The aim of the locking Prevision® revision prosthesis is to return to a proximal force transfer situation. The reconstitution of the bone stock and the sustainable regeneration of the defect are prerequisite for the proximal bone support and a continuous stable fixation of the implant. Load transfer via the locking screws is only possible for a limited period. When osseous implant stabilization is complete, the locking screws are removed. The decision of when this should take place (usually 1 - 2 years post-op) and the necessity for explantation lies with the surgeon and depends on the individual starting situation and the subsequent history of the treatment.

Then the torque wrench and counter holder are attached. For joining the implant components, the counter holder is held firmly and the tension nut is tightened by turning the torque wrench clockwise (close), until it releases. The torque wrench should be released and retightened after a short rest period until the final torque is achieved.

The coupling mechanism is finally sealed with the closing cap supplied with the proximal implant components.

10 Concluding trial reduction and closure of the osteotomy:
 A final check is made on joint movement, muscular tension and leg length. If the transfemoral approach was used, the osteotomy is closed and fixed with cerclage wires. Major gaps in the bone are reduced by adjusting the position of the bone flap or by filling with additional bone material. The fixa-

tion holes in the lateral trochanter wing of the proximal component allow additional fixation of the implant to the trochanter.

PREVISION® – operating technique

Extrasosseous assembly

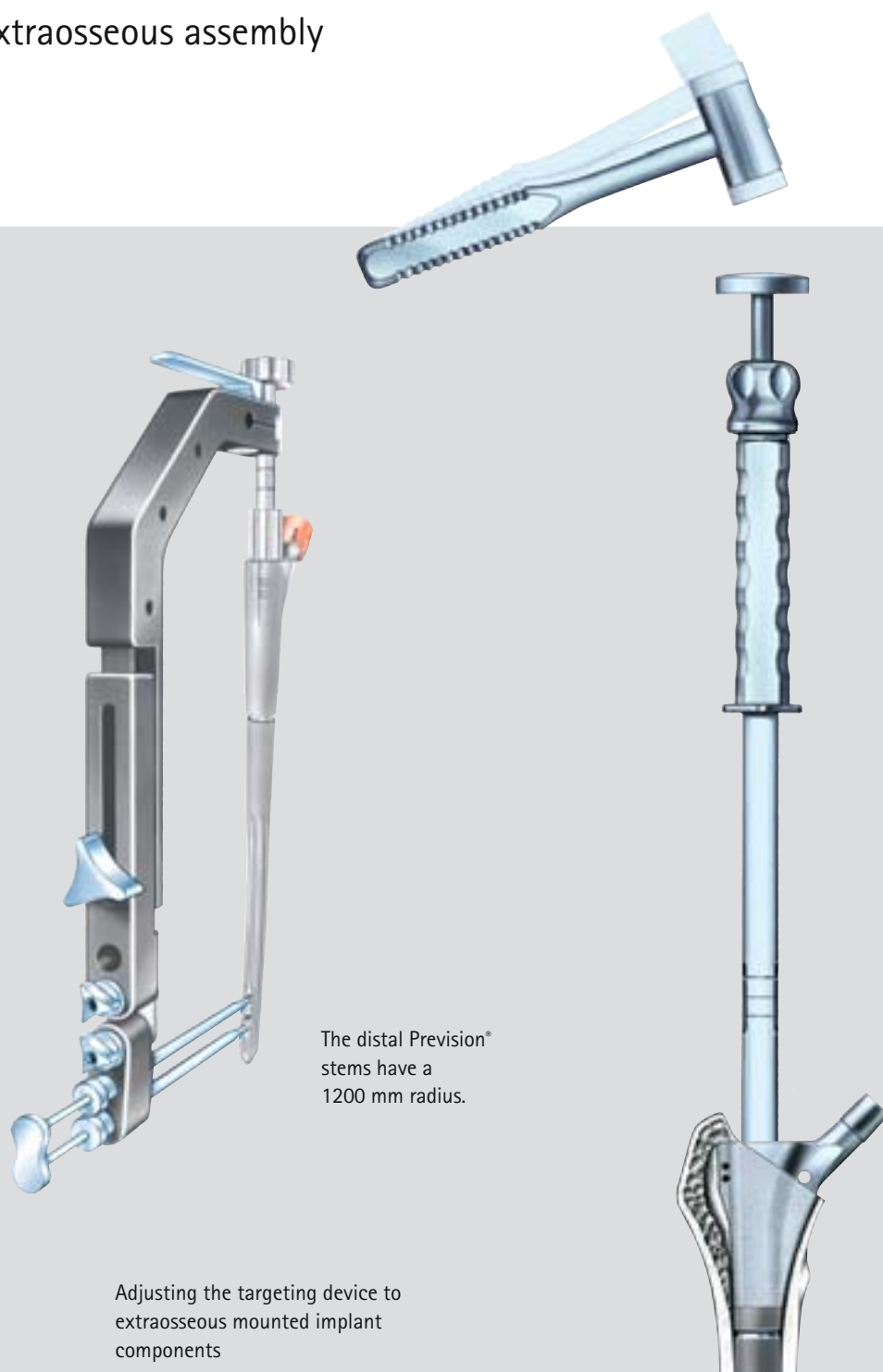

The distal Prevision® stems have a 1200 mm radius.

Adjusting the targeting device to extrasosseous mounted implant components

11 Distal locking of extrasosseous mounted Prevision® implant components:

Where there is inadequate primary stability, especially in proximal and subproximal osseous defects, and as a matter of principle when using the transfemoral approach, the prosthesis is locked distally. This locking can be performed freehand under image intensifier control or using a special targeting device. If this device is to

be used, it is first adjusted to the individual prosthesis before the stem is implanted. To do this, the targeting device is attached to the aiming support that is firmly fixed onto the assembled implant and adjusted according to the screw holes on the stem using a targeting guide. The screws of the targeting device are firmly tightened from a proximal to a distal direction.

If the targeting guide becomes

twisted, all the screws must be loosened and the targeting device reorientated and refixed into position to guarantee correct function. The targeting device is then removed and stored safely during implantation of the stem, following which it is reattached. The tissue protection sleeves serve as the working channel for drilling, measuring and inserting the locking screws.

12 Inserting the extrasosseous mounted Prevision® implant components:

The Prevision® implant components can be assembled analog to the already described intrasosseous method also extrasosseous. The selection of the stem size to be inserted is based on the final used distal and proximal rasps. With transfemoral access and in the lack of subproximal support, the next larger implant diameter in comparison to the final used distal rasp is selected. The implant manually assembled with the torque wrench is screwed on the proximal implantation instrument and under consideration of the ante-torsion position carefully inserted in the femur. The desired implant position is achieved by hammer strokes on the impaction support which is inserted in the proximal implantation instrument.

⚠ Hammering in of the prosthesis only with the impaction support in order to prevent irreversible damage to the cone fixation.

After implantation, check the tightness of the implant components once again with the torque wrench.

Correction and explanation possibilities

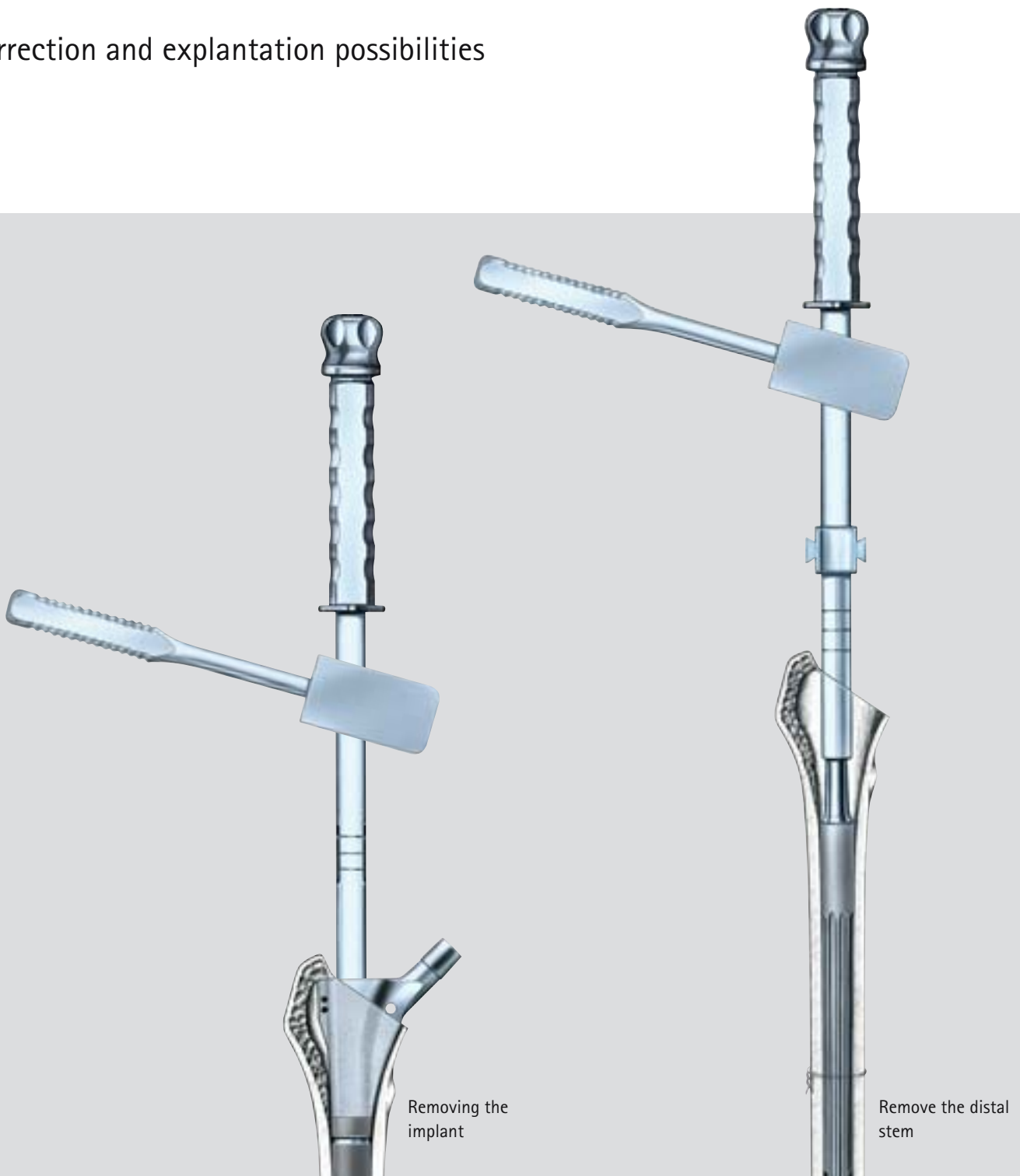

Removing the prosthesis stem (proximal and distal components together):

The already inserted locking pins and the closure cap are removed. The proximal implantation instrument is screwed on the proximal implant component and thereafter the prosthesis shaft completely hammered out with the slotted hammer.

Removal of the distal prosthesis components:

The already inserted locking pins are removed. The distal implantation instrument is screwed on the distal implant component and thereafter the prosthesis shaft completely hammered out with the slotted hammer.

Implant components

Proximal implant components	+0 mm	+10 mm	+20 mm
Size P1	NC091T	NC171T	NC181T
Size P2	NC092T	NC172T	NC182T
Size P3	NC093T	NC173T	NC183T

* Proximal diameter: P1 17 mm, P2 19 mm and P3 21 mm.

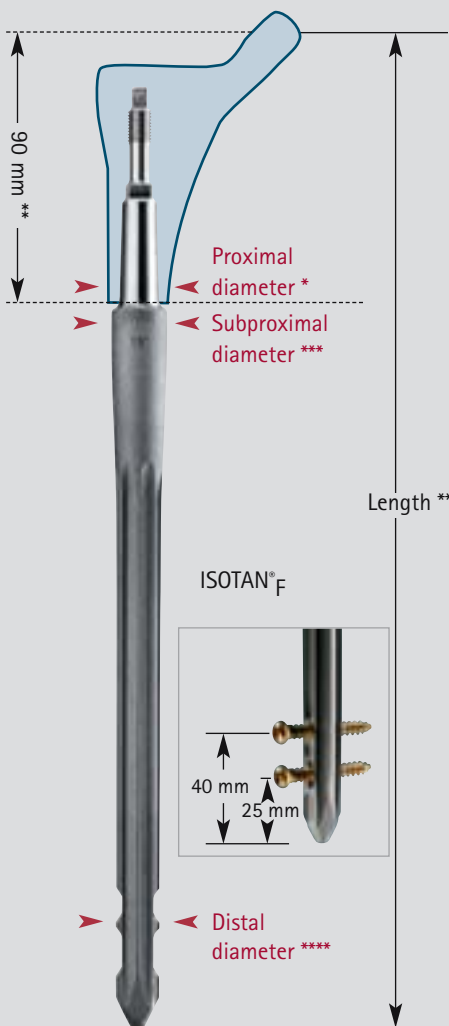

Distal implant components	Ø 12	Ø 14	Ø 16	Ø 18	Ø 20	Ø 22	Ø 24
Length 240 mm	NC041T	NC042T					
Length 280 mm	NC151T	NC152T	NC153T	NC154T	NC155T	NC156T	NC157T
Length 320 mm	NC161T	NC162T	NC163T	NC164T	NC165T	NC166T	NC167T
Length 360 mm		NC132T	NC133T	NC134T	NC135T	NC136T	NC137T
Length 400 mm		NC142T	NC143T	NC144T	NC145T	NC146T	NC147T

** The lengths specified refer to the +0 mm proximal implant components

*** The largest subproximal diameter is 4 mm bigger than the nominal size of the distal implant components.

**** The distal diameter corresponds to the nominal size of the distal implant components.

X-ray templates Prevision shaft

X-ray templates	
ml projection	ND552
ML-Projektion	ND554

Interlocking screws

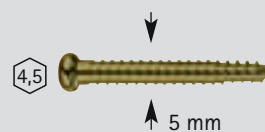

Length	24 mm	28 mm	32 mm	36 mm	40 mm	44 mm	48 mm	52 mm	56 mm	60 mm
	KB424TS	KB428TS	KB432TS	KB436TS	KB440TS	KB444TS	KB448TS	KB452TS	KB456TS	KB460TS

ISOTAN[®] F

Note: The interlocking screws are delivered sterile and substitute the references KB424T – KB460T.



Prosthesis heads

Ceramic prosthesis heads



12/14

	28 mm	32 mm
short	NK460	NK560
medium	NK461	NK561
long	NK462	NK562

BILOX® forte



12/14

	Ø 32 mm	Ø 36 mm
short	NK560D	NK650D
medium	NK561D	NK651D
long	NK562D	NK652D
x long	NK563D	NK653D

BILOX® delta

BILOX® Option Prosthesis heads



12/14

	Ø 28 mm	Ø 32 mm	Ø 36 mm
short	NK435	NK535	NK635
medium	NK436	NK536	NK636
long	NK437	NK537	NK637
x long	NK438	NK538	NK638

BILOX® delta with sleeve Ti6Al4V

Implant materials:

ISOTAN[®]_F Titanium forged alloy (Ti6Al4V / ISO 5832-3)
 ISOTAN[®]_P Pure titanium (Ti / ISO 5832-2)
 Plasmapore[®] μ-CaP Pure titanium surface with 20 μm layer dicalcium phosphate dihydrate (CaHPO₄·2H₂O)

Metal head



12/14

	22.2 mm	28 mm	32 mm
short	–	NK429K	NK529K
medium	NK330K	NK430K	NK530K
long	NK331K	NK431K	NK531K
x long	–	NK432K	NK532K
xx long	–	NK433K	NK533K

ISODUR[®]_F

Recon Ring

Fitting x-ray template: ap projection NG340



	right	left	recommended PE cup
52 (48)	NH212T	NH222T	Ø 46 mm
58 (54)	NH233T	NH243T	Ø 52 mm
64 (60)	NH254T	NH264T	Ø 58 mm

ISOTAN[®]_P

Fixation screws for Recon ring

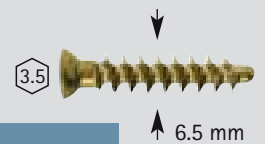

16 mm	NA766T	44 mm	NA794T
20 mm	NA770T	48 mm	NA798T
24 mm	NA774T	52 mm	NA802T
28 mm	NA778T	56 mm	NA806T
32 mm	NA782T	60 mm	NA810T
36 mm	NA786T	64 mm	NA814T
40 mm	NA790T	68 mm	NA818T

ISOTAN[®]_F

ISODUR[®]_F Cobalt-chromium forged alloy (CoCr29Mo / ISO 5832-12)
 Biolox[®] forte Aluminum oxide ceramic (Al₂O₃ / ISO 6474)
 Biolox[®] delta Al₂O₃ Ceramic matrix composite
 UHMWPE Ultra-high molecular weight polyethylene ISO 5834-2

Instruments

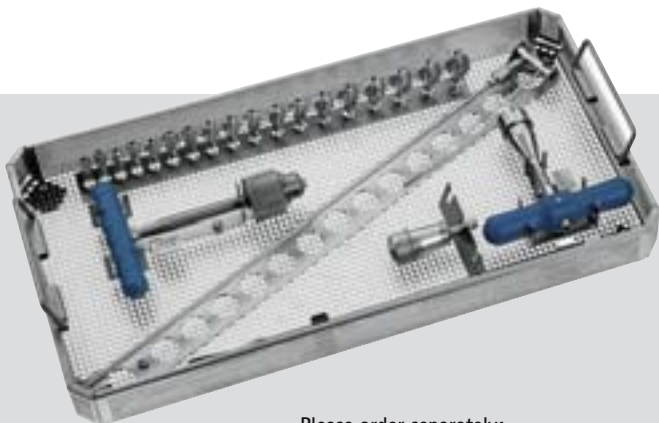

Please order separately:
AO large chuck GB422R
with Harris shank



Please order separately:
Trial head Ø 32 mm, S NG306
Trial head Ø 32 mm, M NG307
Trial head Ø 32 mm, L NG308
Trial head Ø 32 mm, XL NG309



Recommended container
for NG864, NG852 and NG854
Aesculap basic container 592 x 285 x 205 mm
for NG856 and NG858
Aesculap basic container 592 x 285 x 138 mm
for NG860 and NG862
Aesculap basic container 592 x 285 x 138 mm

NG864 Prevision set of MFR medullary canal reamers comprising:

Perforated tray with lid 485 x 254 x 50 mm					NG865R
Medullary canal reamer head	Ø 10	Ø 11	Ø 12	Ø 13	Ø 14
	GE670R	GE672R	GE674R	GE676R	GE678R
	Ø 15	Ø 16	Ø 17	Ø 18	Ø 19
	GE680R	GE682R	GE684R	GE686R	GE688R
	Ø 20	Ø 21	Ø 22	Ø 23	Ø 24
	GE690R	GE691R	GE692R	GE693R	GE694R
MFR guide wire Ø 2.5 mm L800 mm					GE663S
MFR Nitinol drill shaft, AO large shank					GE666R
T-handle, canulated, AO large chuck					ND134R
T-handle, universal, AO large chuck					KH319R
Rigid reamer Ø 12 mm					ND567R

NG852 Prevision set of proximal rasps comprising:

Perforated tray 485 x 254 x 70 mm				NG853R
Proximal trial implant	+0 mm	+10 mm	+20 mm	
P1 (green)	NF791P	NF801P	NF821P	
P2 (yellow)	NF792P	NF802P	NF822P	
P3 (blue)	NF793P	NF803P	NF823P	
Trial head	S	M	L	XL
Ø 28 mm	NG296	NG297	NG298	NG299
Proximal rasp P1				NG801R
Proximal rasp P2				NG802R
Proximal rasp P3				NG803R
Modular handle				NG115R
T-handle for rigid reamer				ND144R
Screwdriver				ND566R
Trial tension nut				NG599R

NG854 Prevision set of distal rasps 240 – 320 mm comprising:

Perforated tray 485 x 254 x 50 mm					NG855R
Distal rasp	Ø 12	Ø 14	Ø 16	Ø 18	
Length 240 mm	NG595R	NG596R			
Length 280 mm	NG811R	NG812R	NG813R	NG814R	
Length 320 mm	NG821R	NG822R	NG823R	NG824R	
	Ø 20	Ø 22	Ø 24		
Length 280 mm	NG815R	NG816R	NG817R		
Length 320 mm	NG825R	NG826R	NG827R		



Please order separately:
Aiming support ND582R

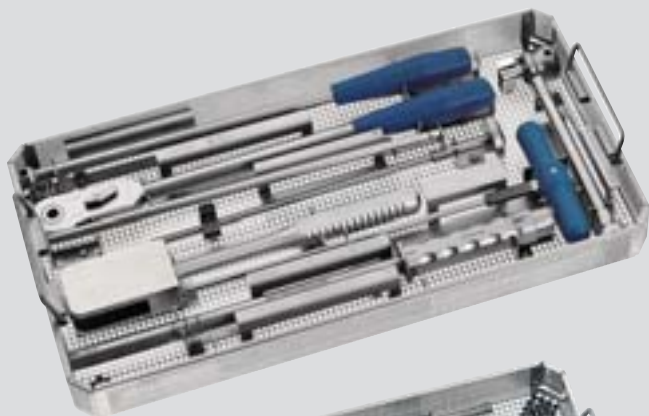

Not illustrated: Targeting device NF510
See Aesculap brochure O 107 02 for description
Note: Extension NF503R for stem length of the
targeting device 360 – 400 mm should be
ordered separately.

NG856 Prevision implantation instruments set 1 comprising:

Perforated tray 485 x 254 x 50 mm	NG857R
Proximal implantation instrument	ND562R
Distal implantation instrument	ND563R
Drilling sleeve	LS110R
Screwdriver size SW4.5	KH322R
Screw gauge	ND574R
Twist drill Ø 3.5 mm	KH287R
Twist drill Ø 5.0 mm	KH288R

NG858 Prevision implantation instruments set 2 comprising:

Perforated tray 485 x 254 x 50 mm	NG859R
Slotted hammer	ND565R
Separator	ND564R
Implantation instrument for distal rasps	ND568R
Torque wrench with socket key	ND570R
Counter holder with socket key	ND572R
Impaction support	ND583R

NG860 Prevision set of distal rasps 360 mm comprising:

Perforated tray 485 x 254 x 50 mm	NG861R		
Distal rasp	Ø 14	Ø 16	Ø 18
Length 360 mm	NG832R	NG833R	NG834R
	Ø 20	Ø 22	Ø 24
Length 360 mm	NG835R	NG836R	NG837R

NG862 Prevision set of distal rasps 400 mm comprising:

Perforated tray 485 x 254 x 50 mm	NG863R		
Distal rasp	Ø 14	Ø 16	Ø 18
Length 400 mm	NG842R	NG843R	NG844R
	Ø 20	Ø 22	Ø 24
Length 400 mm	NG845R	NG846R	NG847R



AESCULAP®

B | BRAUN
SHARING EXPERTISE

Aesculap AG

Am Aesculap-Platz
78532 Tuttlingen
Germany

Phone +49 7461 95-0
Fax +49 7461 95-2600

www.aesculap.de

Technical changes reserved. This prospect may exclusively serve for offering and the purchase and sale of our products. Reproduction, also partial, is prohibited. Upon violation, we reserve the right to retrieve the catalogs and price lists as well as to claim for damages.